

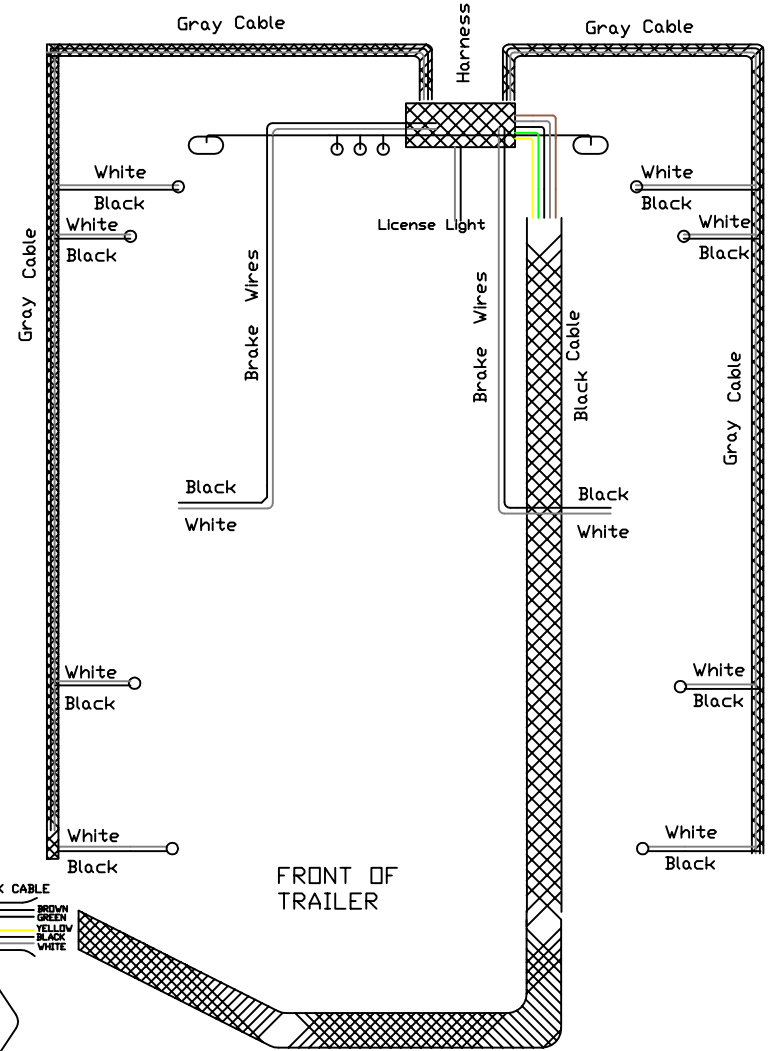

WHITE----GROUND
 BLACK----BRAKES
 YELLOW---LEFT TURN
 RED-----CHARGE TO BATTERY
 GREEN----RIGHT TURN
 BROWN----RUNNING LIGHTS

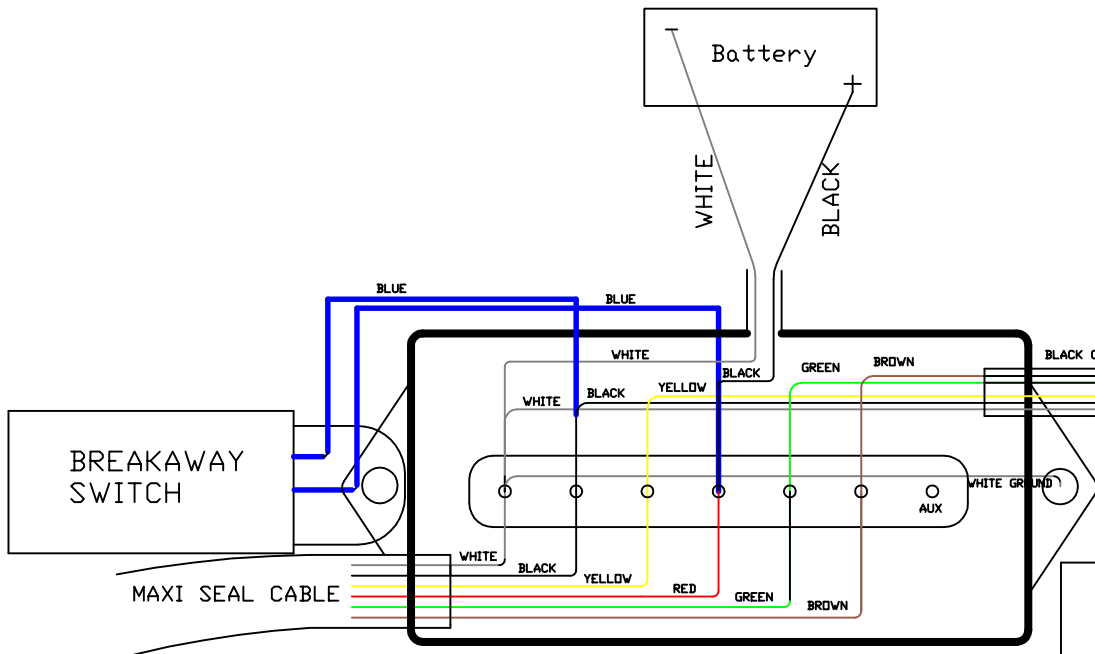
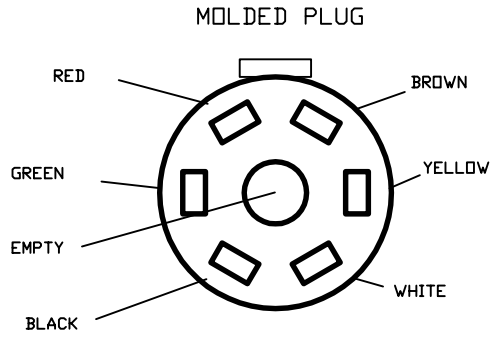

BUMPER PULL DUMPS		PART NO:	
		PART NO.	
MAT'L: WIRING DIAGRAM		ALL DIMENSIONS IN FEET/INCHES (UNLESS OTHER- WISE NOTED)	
SCALE:	LAST REV.	PHONE: 903-785-6879	FAX: 903-785-6898
DRAWN: RRU	CHK.:	APP.:	THIS DRAWING, INCLUDING THE PRINCIPLE OF DESIGN, IS THE PROPERTY OF PJ TRAILERS MFG. AND MUST NOT BE USED FOR ANY PURPOSE DETRIMENTAL TO OUR INTEREST.